



SD-QDT

Air Quality Transmitter



SENSOR DATA

SD-QDT

Air Quality Transmitter

The duct air quality transmitters QDT-series is used to determine the air quality, based on a mixed gas sensor (VOC sensor).

The duct air quality transmitters QDT-series is designed to measure the air quality in offices, hotels, meeting rooms, convention centres, schools, airports, apartments, stores, restaurants etc.



FEATURES

- 0-10 Vdc or 4-20 mA or 0-20 mA output (selectable)
0-10 Vdc: 0 Vdc = clean air, 10 Vdc = polluted air
4-20 mA: 4 mA = clean air, 20 mA = polluted air
0-20 mA: 0 mA = clean air, 20 mA = polluted air
- Change-over contact for QDT S
- Display for QDT D
Display show air quality in procent (0% to 100%)
0% is clean air
100% is polluted air

DETECTABLE GASSES

- Cigarette smoke
- Automobile exhaust
- Breath air
- Carbon dioxide (CO₂)
- Carbon monoxide (CO)
- Solvent fumes
- Alcohol fumes
- Acetone
- Acrylonitrile
- Ammonia
- Benzene
- Chlorine
- Dimethyl amine
- Ethane
- Ethylene
- Ethylene oxide
- Formaldehyde
- Hydrogen
- Hydrogen sulfide
- Isobutane
- Methane
- Methanol
- Methyl chloride
- Methylene chloride
- Methy ether
- Methyl acetate
- Methyl ethyl ketone
- n-Hexane 2
- n-Petane
- Propane
- R-11
- R-12
- R-502
- R-123
- Sulfur dioxide
- Vinyl chloride

Technical data

Sensor	VOC sensor (metal oxide) with automatic self-calibration
Sensor protection	sinter filter, exchangable, screwed, easy to clean
Measuring range	0-100% air quality referred to calibration gas multi-range switching (selectable DIP switches) VOC: LOW - MEDIUM - HIGH
Measuring accuracy	+/- 20% EW of final value (referred to calibration gas)
Power supply	24 Vac/dc
Current consumption	ca. 70 mA at 24V
Output(s)	0-10 Vdc, 4-20 mA or 0-20 mA (selectable)
Switch output (only QDT S)	potential-free changeover contact (24V) switch point adjustable from 0-100% of the output signal.
Ambient temp.range	0 to +50°C
Detection of gases	not selective
Long-term stability	< 10% per year
Warm-up period	1 hour
Response time	< 60 sec.
Housing material	Plastic, material polyamide 30% glassglobe-reinforced with quick-locking screws, colour pure white (similar RAL9010)
Probe	material= metal, lenght 190 mm, dia 16 mm
Protection type	IP 65
Protection class	III
Approval	CE-conformity, electromagnetic compability according to EN 61326+A1+A2, EMC directive 2004/108/EC

Order Codes

Type no.	Description
QDT	Output 0-10 VDC, 4-20 mA or 0-20 mA (selectabel)
QDT-S	same as QDT and change-over contact (normally open)
QDT-D	same as QDT and with display

Use of SD-QDT

The self-calibrating microprocessor-controlled duct air quality transmitter is used to determine the air quality on basis of a mixed gas sensor / VOC sensor (VOC = volatile organic compounds).

It is used for:

- Air quality measurement in offices, hotels, meeting rooms and convention centres, apartments, stores, and restaurants, etc.
- Quantitative evaluation of room air pollution with contaminating gases (cigarette smoke, body perspiration, exhaled breathing air, solvent vapours, emissions from building members and cleaning agents).
- Adjustable sensitivity regarding the maximum air contamination to be expected.
- For room ventilation as-needed, enabled by air changes only taking place when air is polluted while conserving energy at the same time.

Room air quality is understood as subjective air quality, felt by human beings with their olfactoryorgans.

As perception varies from person to person and therefore, air quality is assessed differently, a general definition of criteria for room air quality is not possible.

By linearising and high operating temperatures, the air quality sensor achieves marginal drift and good stability.

The sensor is automatically self-calibrating.

The air quality sensor does not trace the concentrations of individual gases, but assesses the mixed gas as such, i.e. gas concentrations are not measured selectively.

Therefore, it is not possible to specify gas concentrations by the unit ppm.

Detectable gases: mixed gas, vapours of alcanoles, cigarette smoke, automobile exhaust gases, exhaled breathing air, combustion smoke (from wood, paper, plastics).

In addition, compounds of alkanes, alkenes, aromats, terpenes, halogenated hydrocarbons, esters, aldehydes and ketones as well as native VOCs such as terpenes and isoprene are ranking among volatile organic compounds VOC.

VOCs also evaporate from chemical products used in construction such as coating compounds, adhesives, or sealing compounds, furnishing objects, cleaning and care products, office chemicals and floor carpeting.

The sensor's service life is depending on the type of burden and gas concentration and is more than 60 months under normal load conditions.

The new design implies the alternative to choose between three sensibility ranges by means of DIP switches, comparable to three measuring ranges: LOW for low, MEDIUM (default, equivalent to the hitherto existing type of this device) for medium, and HIGH for high noxious gas contaminations.

Electrical connections

QDT and QDT D

1	- GND
2	+ Power supply 24 Vac/dc
3	GND
4	Output 0-10 Vdc, 4-20 mA or 0-20 mA

QDT S

1	- GND
2	+ Power supply 24 Vac/dc
3	GND
4	Output 0-10 Vdc, 4-20 mA or 0-20 mA

5	Normal open	
6	contact	
7	Breaker	

Schematic diagram

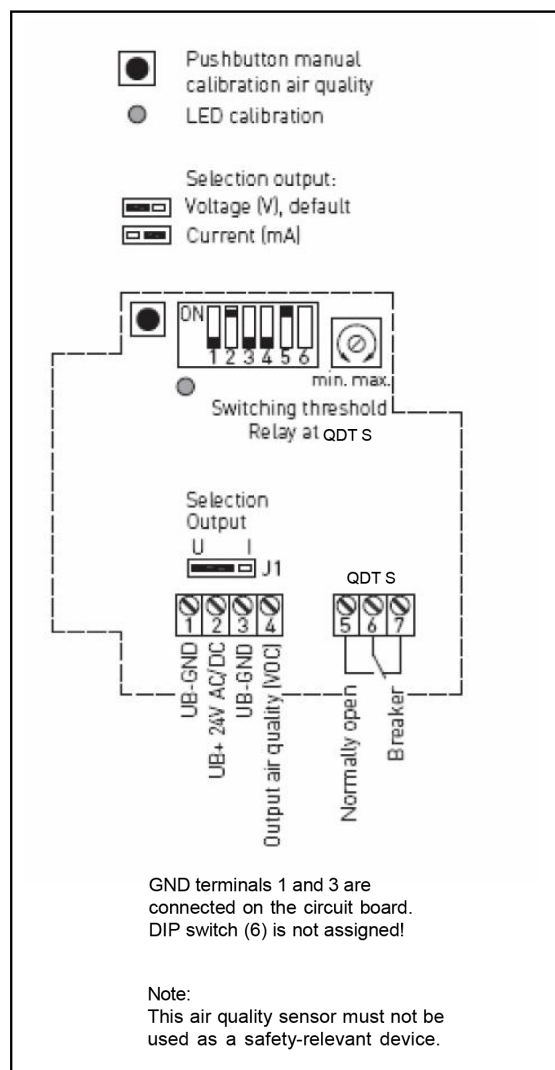

Multi-range switching

VOC (sensitivity adjustable)	DIP 1	DIP 2	DIP 3
VOC LOW	ON	OFF	OFF
VOC MEDIUM (default)	OFF	ON	OFF
VOC HIGH	OFF	OFF	ON
VOC Calibration mode			DIP 4
Automatic self-calibration			OFF
Manual calibration			ON
Output selection			DIP 5
Output 0 ...20 mA			OFF
Output 4 ...20 mA			ON



Supply Voltage

For operating voltage reverse polarity protection, a one-way rectifier or reverse polarity protection diode is integrated in this device variant.

This internal one-way rectifier also allows operating 0-10 Vdc devices on AC supply voltage.

The output signal is to be tapped by a measuring instrument. Output voltage is measured here against zero potential (0 V) of the input voltage!

When this device is operated on DC supply voltage, the operating voltage input UB+ is to be used for 15 to 36 V DC supply and UB- or GND for ground wire!

When several devices are supplied by one 24 V AC voltage supply, it is to be ensured that all "positive" operating voltage input terminals (+) of the field devices are connected with each other and all "negative" operating voltage input terminals (-) (= reference potential) are connected together (in-phase connection of field devices).

All outputs of field devices must be referenced to the same potential!

In case of reversed polarity at one field device, a supply voltage short-circuit would be caused by that device. The consequential short-circuit current flowing through this field device may cause damage to it.

Therefore, pay attention to correct wiring!

Connection scheme

Individual operation

Power supply

AC 24V~ | 0V
DC 15-36V = | GND

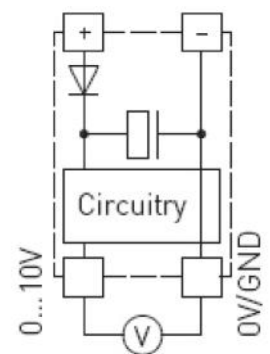

Connection scheme

Parallel operation

Power supply

AC 24V~ | 0V
DC 15-36V = | GND

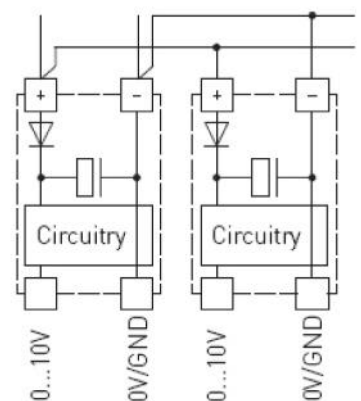

Dimensions

Dimensions in mm for QDT and QDT S

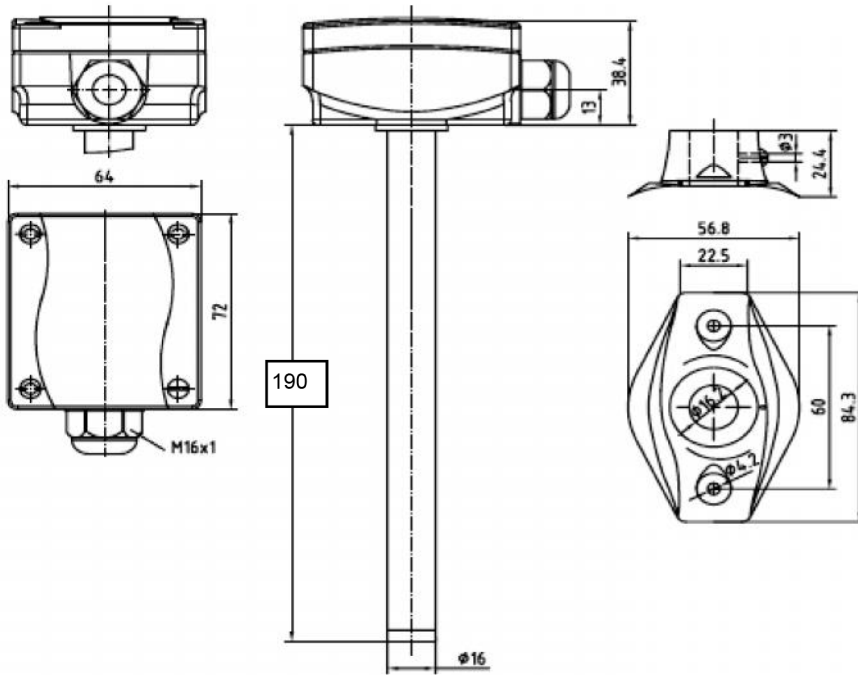

Dimensions in mm for QDT D

